

WEBEL TECHNOLOGY LIMITED

NOTICE INVITING e-TENDER

Online Tender documents are invited for Installation of Grid-Connected Rooftop Solar Panel at Dakshin Dinajpur Zilla Parishad office Building, Government of West Bengal.

Reputed entities/organizations having sufficient experience and credentials for successful completion of “**Similar Nature**” of work in a Government Department/PSU/Autonomous Body or any reputed organization. Bidder must have adequate experience and expertise on aforesaid subject.

1.	Tender No. & Date	WTL/DDZP/SOLAR/25-26/017 dated 08.08.2025
2.	Tender Version No.	1.0
3.	Brief description of Job	Installation of Grid-Connected Rooftop Solar Panel at Dakshin Dinajpur Zilla Parishad office Building, Government of West Bengal. (The entire warranty period, i.e., Solar PV 25 (Twenty-Five) years and Inverter and necessary deliverables 5 (Five) years)
4.	Tender Fee	Rs. 5,000.00 (Rupees Five thousand only) The amount to be transferred online through e-Tender portal.
5.	Earnest Money Deposit	Rs. 1,20,000.00 (Rupees One Lakh Twenty Thousand only) The amount to be transferred online through e-Tender portal.
6.	Date of Downloading	08.08.2025
7.	Pre-Bid Meeting date & time	14.08.2025 at 12.00 Hrs.(On-Line Meeting) <ul style="list-style-type: none">• Pre-Bid meeting will be held ONLINE.• Only queries as per format (Section - R) reaching WTL by 13.08.2025 at 15.00 Hrs. will be taken for decision.• Interested bidders are requested to send mail to purchase@wtl.co.in for participation of online pre-bid meeting. Based on request WTL will share meeting id / links for meeting.• Queries will be sent to Manager (Purchase)(purchase@wtl.co.in)
8.	Bid Submission Start date & time	19.08.2025 at 12.00 Hrs
9.	Last date & time of EMD & Tender Fee submission	Before Uploading of Tender
10.	Last date & time of Bid Submission	22.08.2025 at 12.00 Hrs
11.	Date & time of Technical Bid Opening	25.08.2025 at 11.00 Hrs
12.	WTL Address	WEBEL TECHNOLOGY LIMITED (A Govt. of West Bengal Undertaking) Plot - 5, Block – BP, Sector – V, Salt Lake City, Kolkata – 700091. E-mail – purchase@wtl.co.in
13.	WTL Contact Person	033-23673403-06

WEBEL TECHNOLOGY LIMITED

1. Intending bidder may download the tender documents from the website <https://wbtenders.gov.in> directly with the help of Digital Signature Certificate. Necessary Tender fee may be remitted electronically through e-tender portal in favour of “Webel Technology Limited” and also to be documented through e-filing. Necessary Earnest Money Deposit (EMD) may be remitted electronically through e-tender portal in favour of “Webel Technology Limited” and also to be documented through e-filing.
2. Both Techno Commercial Bid and Financial Bid are to be submitted concurrently duly digitally signed in the website <https://wbtenders.gov.in>
3. Tender documents may be downloaded from website and submission of Techno Commercial Bid and Financial Bid will be done as per Time Schedule stated in Section – C of this Tender Document.
4. The Financial Bid of the prospective Bidder will be considered only if the Techno Commercial Bid of the bidder is found qualified by the Tender Committee. The decision of the ‘Tender Committee’ will be final and absolute in this respect. The list of Qualified Bidders will be displayed in the website.
5. All clarifications / corrigendum will be published only on the WTL Website & <https://wbtenders.gov.in>.

WEBEL TECHNOLOGY LIMITED

CONTENTS OF THE TENDER DOCUMENT

The Tender document comprises of the following:

SECTION – A	SCOPE OF WORK & RESPONSIBILITY
SECTION – B	ELIGIBILITY CRITERIA
SECTION – C	DATE AND TIME SCHEDULE
SECTION – D	INSTRUCTION TO BIDDER
SECTION – E	BID FORM
SECTION – F	TECHNO COMMERCIAL EVALUATION & AWARDING OF CONTRACT
SECTION – G	GUIDANCE FOR E-TENDERING
SECTION – H	BILL OF MATERIAL FOR PROCUREMENT
SECTION – I	TECHNICAL SPECIFICATION WITH COMPLIANCE STATEMENT
SECTION – J	DETAILS OF ORDERS EXECUTED BY BIDDER
SECTION – K	FINANCIAL CAPABILITY OF BIDDER
SECTION – L	BIDDER'S DETAILS
SECTION – M	CHECKLIST FOR ELIGIBILITY/QUALIFICATION CRITERIA COMPLIANC
SECTION – N	LIST OF CLIENTS OF SIMILAR ORDERS
SECTION – O	PROFORMA FOR PERFORMANCE BANK GUARANTEE
SECTION – P	SERVICE LEVEL AGREEMENT
SECTION – Q	NIT DECLARATION FOR BIDDER
SECTION – R	FORMAT FOR PRE-BID QUERIES
SECTION – S	MANUFACTURER'S AUTHORIZATION FORM

WEBEL TECHNOLOGY LIMITED

SECTION – A

SCOPE OF WORK & RESPONSIBILITY

❖ **SCOPE OF WORK:**

The Dakshin Dinajpur Zilla Parishad's initiative to install grid-connected solar power systems of 60.5 KWP and two units of 10K WP each marks a significant step towards sustainable energy integration. These systems will be directly linked to the local power grid, enabling the generation of clean electricity and its seamless distribution to meet the district's energy demands.

✓ **Anticipated Transformations in the Current System**

✓ **Enhanced Energy Reliability and Stability**

- **Grid Stability:** Integrating solar photovoltaic (PV) systems contributes to a more stable and flexible energy grid. By decentralizing energy sources, these systems help balance supply and demand, reducing the risk of outages and enhancing overall grid resilience.
- **Voltage Support:** Solar PV systems can provide reactive power support, maintaining stable voltage levels, especially during peak demand periods. This ensures consistent power quality for consumers.

✓ **Economic and Environmental Benefits**

✓ **Cost Savings:** The generation of solar energy reduces reliance on traditional fossil fuels, leading to decreased energy costs over time. This is particularly beneficial for community services and public infrastructure

- **Environmental Impact:** Shifting to renewable energy sources significantly cuts greenhouse gas emissions, aligning with global efforts to combat climate change and promoting a healthier local environment.

✓ **Technological Advancements and Grid Modernization**

- **Smart Grid Integration:** The adoption of grid-connected solar systems encourages the development of smart grid technologies. These advanced systems facilitate real-time monitoring and management of energy flows, optimizing efficiency and reliability.
- **Energy Storage Solutions:** Incorporating battery storage with solar installations allows for the retention of excess energy produced during peak sunlight hours. This stored energy can be utilized during periods of low production or high demand, ensuring a consistent energy supply.

✓ **Local Initiatives and Applications**

❖ **REQUIREMENT OF PROPOSED SOLUTIONS:**

Implementation of a **60 kW, 10 kW & 10 kW power generation project** at Dakshin Dinajpur Zilla Parishad (here in after referred as “**DDZP DDZP 60 kW, 10 kW &10 kW power generation grid-connected project** to promote sustainable energy utilization, reduce dependency on conventional power sources, and lower electricity costs.

WEBEL TECHNOLOGY LIMITED

Technical Details of Solar PV Power Plant Capacity of 60, 10 & 10kWp

Sl. No	Components	Details
1.	Location	DDZP 60KWp DDZP office Campus Block A, Wing A 10KWp DDZP Office Campus Block A, Wing B 10KWp
2.	Capacity	60, 10 & 10KWp
3.	Type of System	Grid Connected
4.	Expected life of Power Plant	25 Years

❖ ARCHITECTURAL DIAGRAM OF ROOF TOP GRID CONNECTED SOLAR POWER SYSTEM

1. For 60kWp

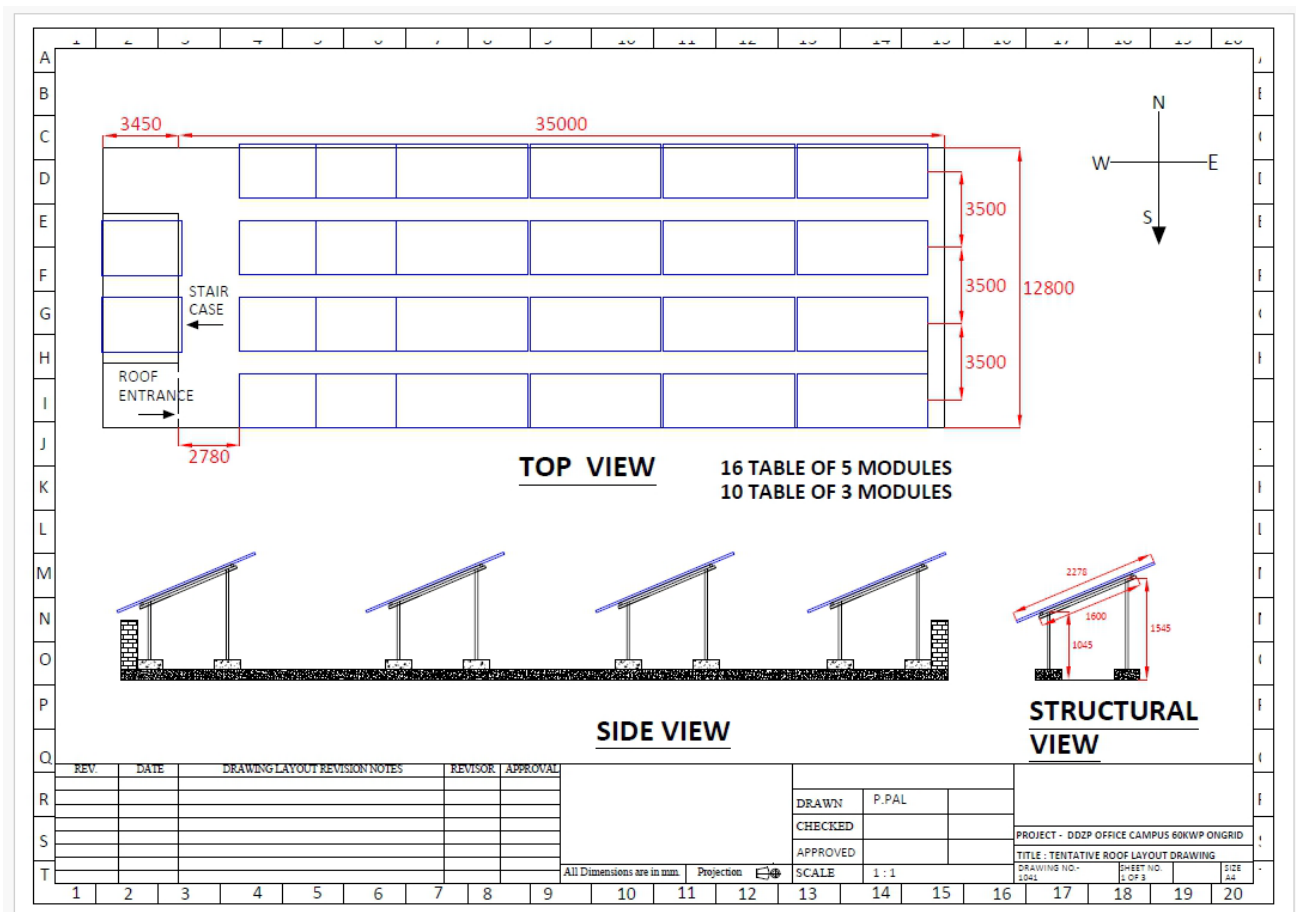

WEBEL TECHNOLOGY LIMITED

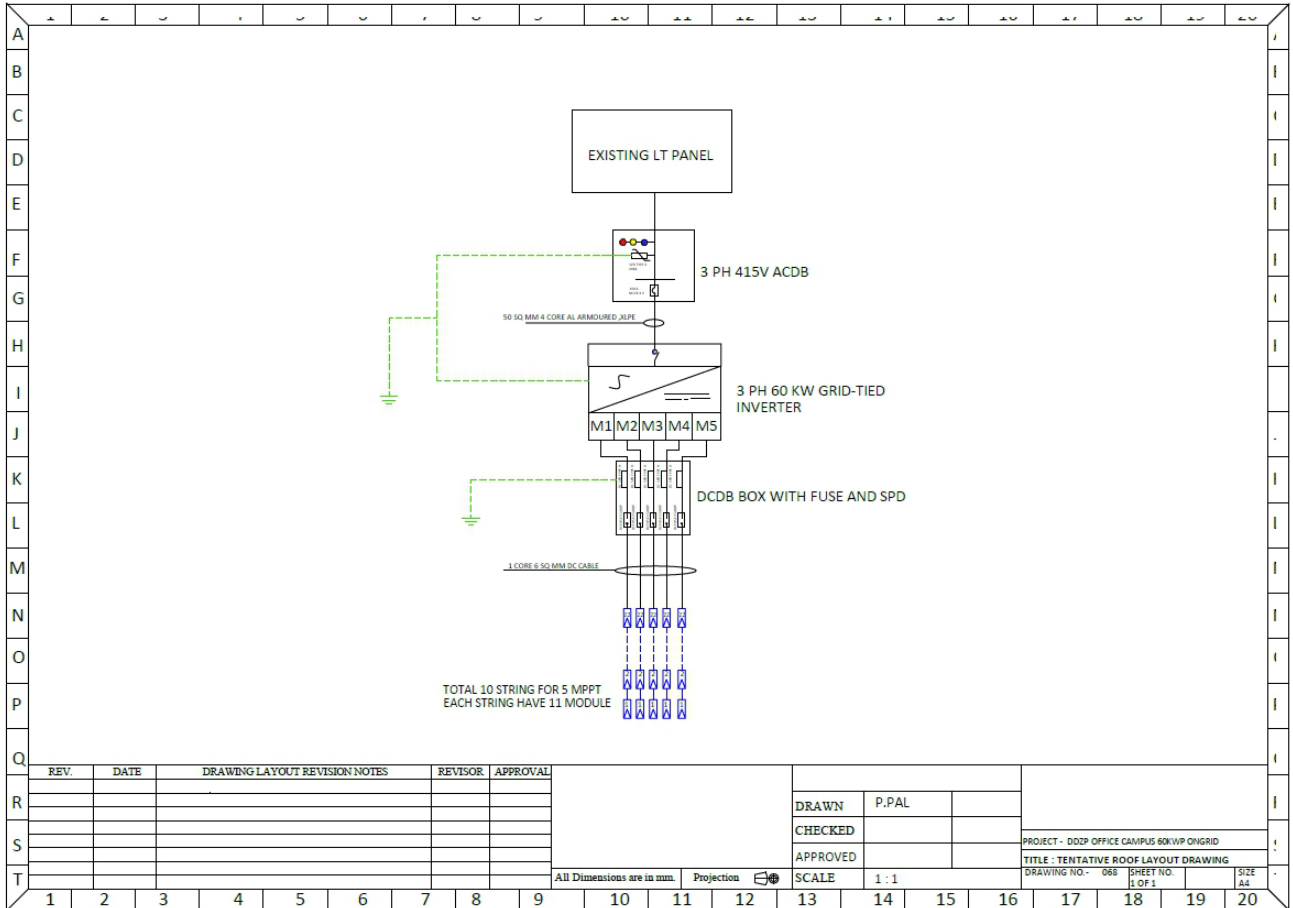

2. For 10kW Block A Wing Model

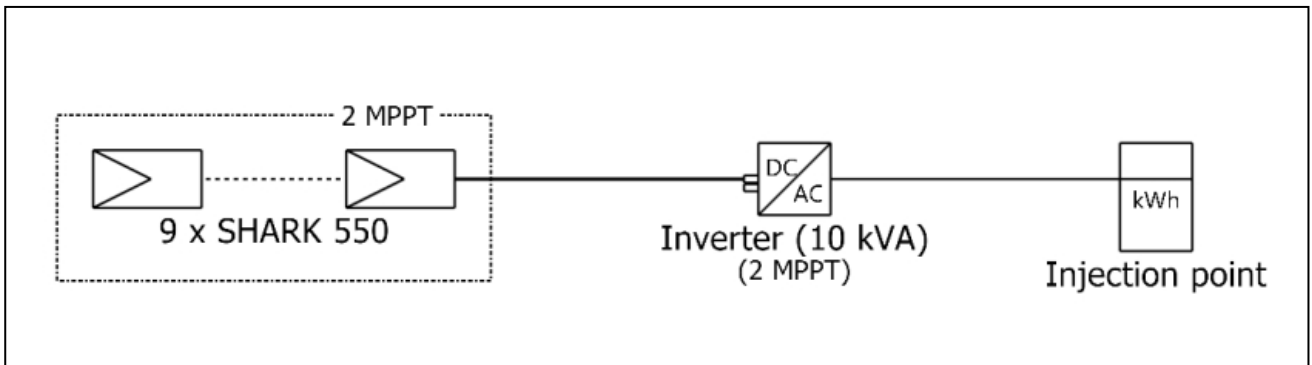

WEBEL TECHNOLOGY LIMITED

2.1. Single Line Diagram

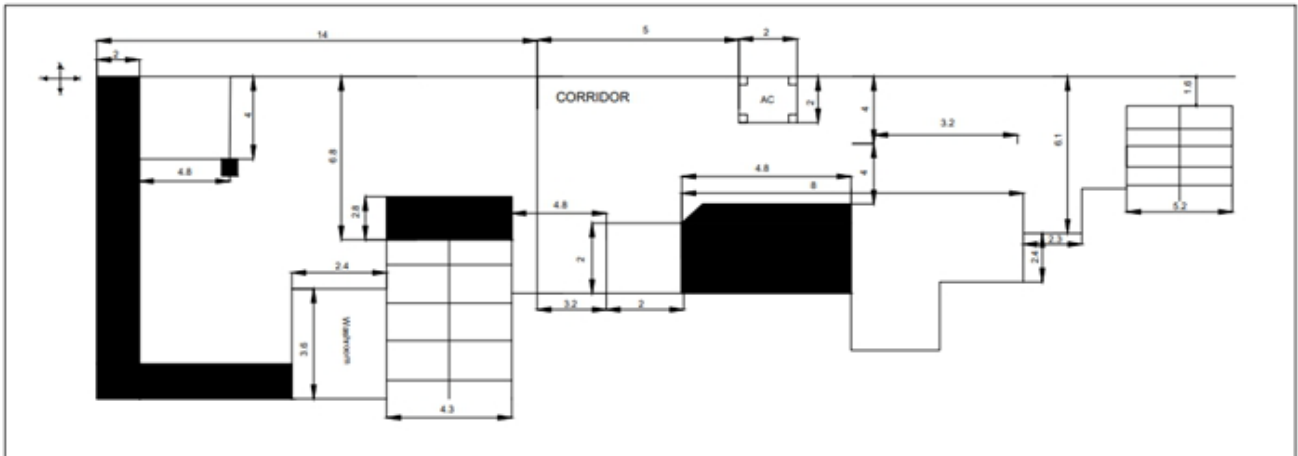

	NAME	DATE	CLIENT- DDZP Office Campus. Block A. Wing: A	PROJECT: DDZP Office Campus. Block A. Wing: A	SHEET NO. -1	
DRAWN	Pritika Pal	19/02/2025			Total Sheet No. -1	
CHECKED	M.M	19/02/2025	TITLE- 10kW Solar Drawing	SCALE:NTS	Rev-1	
APPROVED					DRAWING NO.	JM/14/25

2.2 10kW Solar Drawing

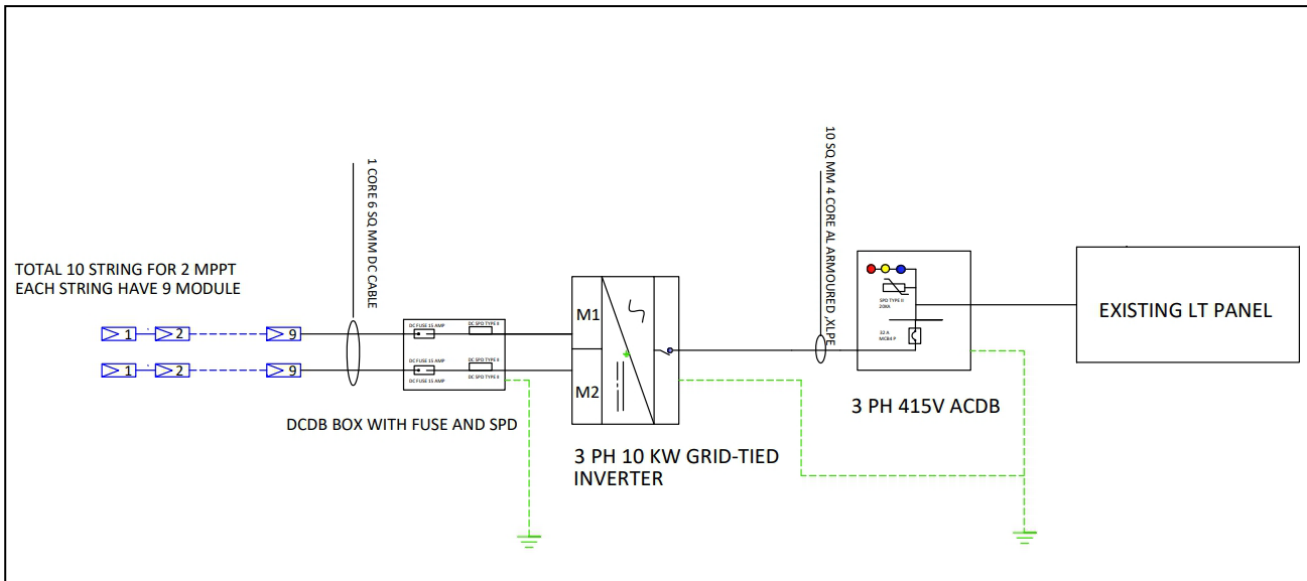

WEBEL TECHNOLOGY LIMITED

2.3 Tentative Roof Top Layout Drawing

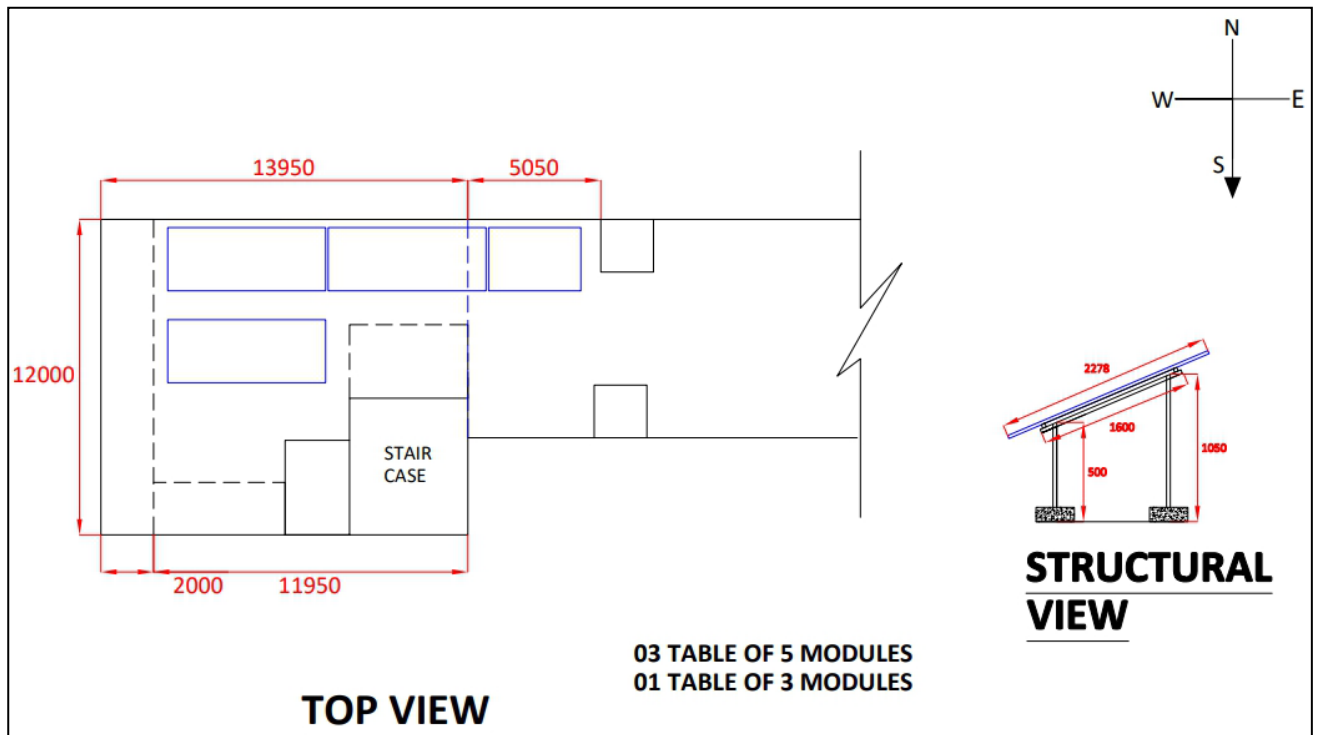

3. For 10kWP Block A Wing B Model:

Sunlight captured by solar panels is converted into DC electricity. This DC electricity is collected from all the solar panels and is passed through an inverter, which converts it into usable AC electricity. This AC electricity is fed into the electricity grid.

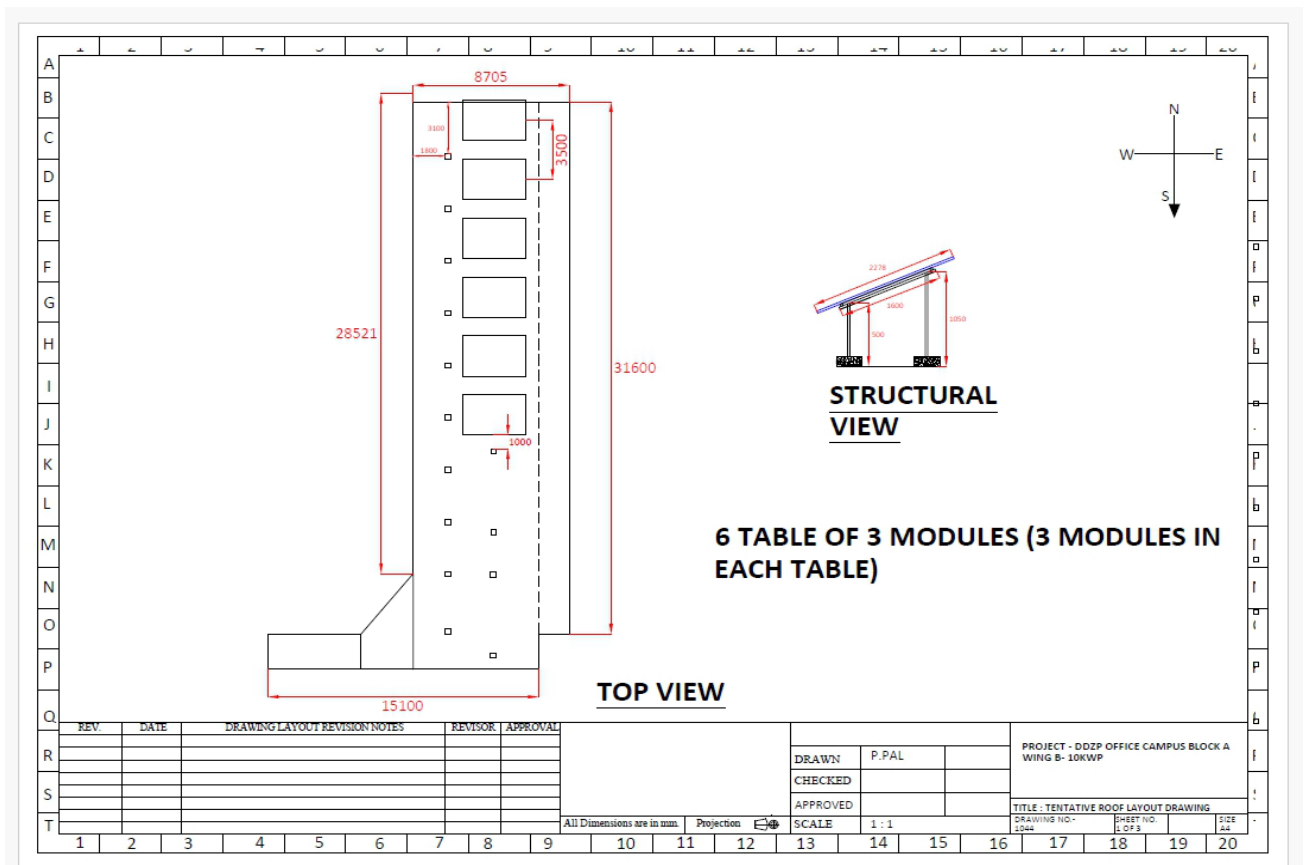

WEBEL TECHNOLOGY LIMITED

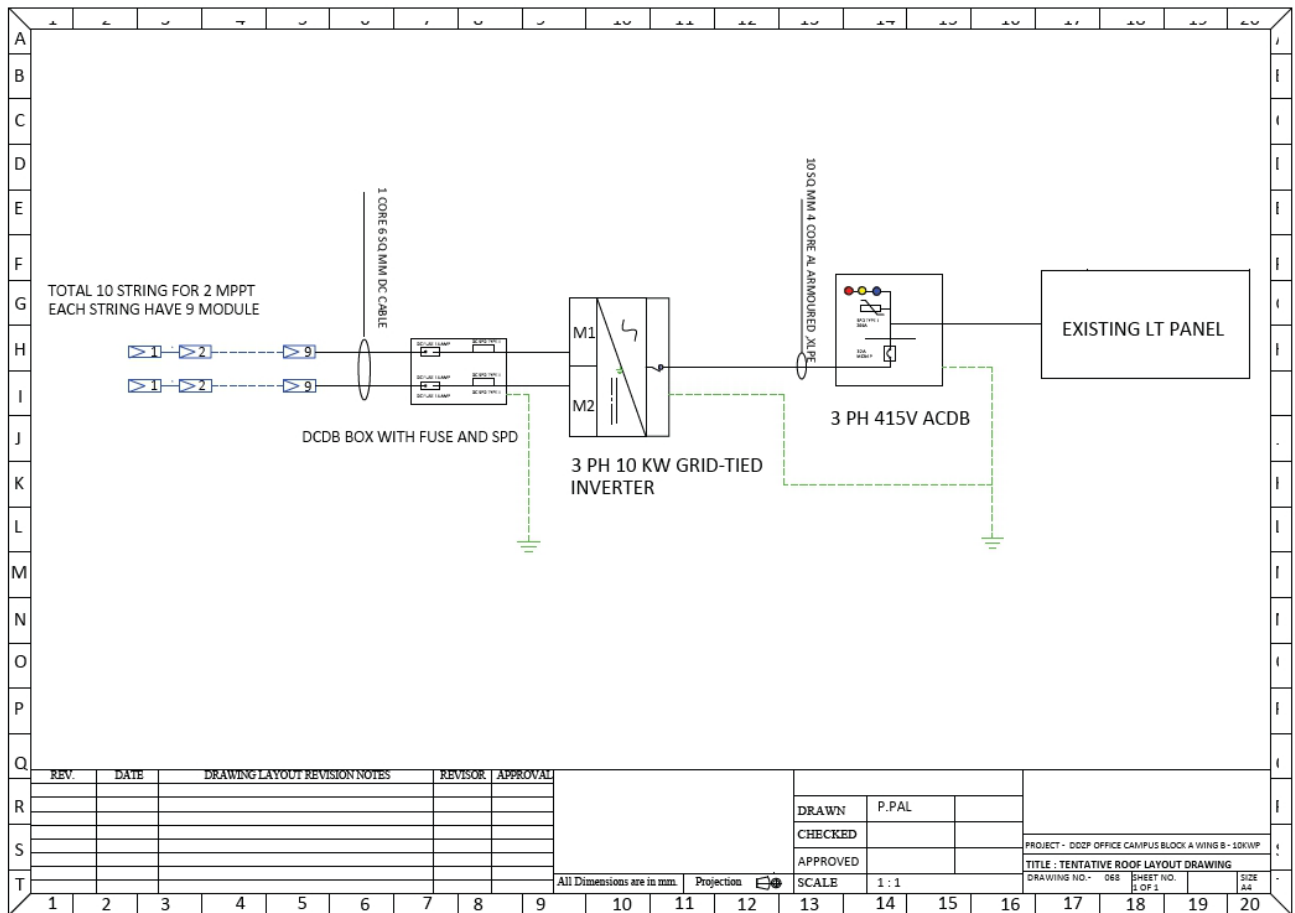

❖ SYSTEM COMPONENTS

1. Mounted System

A fixed mounting structure made up of high strength high performance galvanized steel. Panels are pushed in for faster assembly no nuts and bolts are required. The structure is designed for high speed wind load bearing capacity. The installation and anchorage technology can be drawn from experienced highway crash barrier technology. It can be installed solid Rooftop conditions including solid rock. This mounting system comes with a 5-year warranty.

It is looking forward to a new technology which is Innovative and can be installed without any concrete. This technology is known as screw-pile technology. This technology allows erecting the mounting structure in a very less span of time and has a superior holding capacity with distinct advantage in unstable soils. As with this technology the foundation can be erected in few hrs as there is very less concrete work and the mounting is done by the machines, implementation is swift with several hundred foundation points being completed in a day. A PV Array is made up of PV modules, which are environmentally sealed collections PV cells-the devices that convert sunlight to electricity.

This allows some assembly and wirings functions to be done on the ground if called for by the installation instructions. The panels will be mounted in rows and electrically connected with cables. The cable will need to be made safe and tamper proof. The electrical output from the PV panels will be fed via cables to a bank of inverters.

2. PV Solar Module

Top quality, high efficiency, and high wattage (60, 10 & 10Wp) solar panels are needed in the system.

- PV panels which are used in high efficiency mono crystalline cells and are assembled with top-quality raw materials sourced globally.

WEBEL TECHNOLOGY LIMITED

- Panels should be tested in accordance with IEC 61215, IEC 61730, TUV and UL 1703 certified.
- Best-in-class performance ratings proven by field installations with 25-year power warranty.
- Higher strength with wind and snow loads guaranteed up to 80 lbs/ft²

3. Inverters (CONTROL TECHNIQUES)

The grid tie inverter in a solar PV power plant converts the DC power generated by the PV module in to suitable AC power for feeding to the grid. This inverter automates the startup and shut down functions. By incorporating advanced maximum power point tracking technology, it maximizes the energy harvested for PV modules.

To minimize the power losses during the conversion process, the inverter switching technology should be insulated gate bipolar transistors. Multiple inverters are paralleled for large power installations. High efficiency of conversion under partial load conditions is essential for economic viability of the entire solar power station the inverters with their own weatherproof enclosure installed in close proximity to PV modules are required for this project.

Required Inverter Features

- Enhanced conversion efficiency 98% peak
- Enhanced availability
- Greater Yield at low irradiance
- High accuracy MPPT algorithm over a wide voltage range
- Compact and easy to maintain
- Communications and PC tools for local or remote configuration and monitoring.

Control and Automation

Function of inverter, control and automation forms an integral part of PV system. controller should have following control and automated functions:

- Inverter start up, shut off and disconnection sequence.
- Over/under voltage & frequency protection.
- Anti-islanding protection.
- Power tracking to match inverter to the arrays.
- Adjustment of delay periods to customize system shutdown sequence.
- Graphical user interface for real time communications, monitoring and control.
- Optional remote monitoring via internet modem.
- Faults notification via modem.
- Data acquisition and logging.
- DC monitoring.

4. Monitoring Central System

The system should be an innovative monitoring and analysis system for large PV plants. It should be upgradeable with CAN bus compatible components. The system also enables diagnostic and monitoring functions for these components.

Monitoring of central inverters and junction boxes to string level. Transmits the data required for monitoring, such as yields and the system efficiency to the Internet portal. Here the data is converted into straight forward diagrams and stored. A constant target/actual analysis enable malfunctions to be detected in their initial stages. In such cases, a definable group of persons is notified immediately.

WEBEL TECHNOLOGY LIMITED

Electrical protection equipment will be required to be specified in conjunction with PEA, for the connection of the PV plant to the electrical network.

Highlights:

- Remotely monitor, diagnose, manage and control systems, without costly "truck rolls".
- Receive alerts that serve as early warnings to equipment and system issues.
- Perform remote diagnostics, updates and resets to optimize performance.
- Weid Muller monitoring or equivalent will be used to monitor the performance of the solar power plant.

Features and Benefits:

- Control system based on modular concept easy to adapt to any solar application.
- Integrated strings fuse protection.
- No need of local key-pad programming since all parameters can be set in an easier and quicker manner using software.
- Simplified installation since there is no need of auxiliary bus wiring.

❖ MODULE CLEANING:

Modules are exposed to the environment and depending on the local conditions a dirt layer settles on the modules, which reduces the plant yield. Cleaning is executed by a qualified service provider with a suitable cleaning method including man hours, material and cleaning tools. Service Provider will be responsible for OEM warranty support and comprehensive maintenance of the SPV modules including cleaning for five years. Technical consultants will visit the site once in every quarter of a year.

❖ PROJECT IMPLEMENTATION STRATEGY:

Overall project implementation will have the following stages of activities. These stages are not mutually exclusive; to implement the project on fast-track basis, some degree of overlapping is anticipated.

Stage I – Planning of the Project

Stage II - Finalization of the Equipment and Contracts

Stage III - Procurement and Construction

After receiving of purchase order, the project team will follow up regularly to ensure smooth and timely execution of the contract. The procurement activity includes review of drawings, stage and final pre-delivery inspection, and supervision of installation and construction. During construction, the erection and commissioning phase of multiple contracts will proceed simultaneously.

Stage IV - Erection and Plant Commission

It is the commissioning phase where design, manufacturing, erection and quality assurance expertise are put to test. The commissioning team will consist of key equipment manufacturers of the equipment, engineers, and other specialized experts, where necessary. First step during commissioning is to use a designed check list to ensure that the plant has been properly installed with appropriate safety measures.

The commissioning team will follow the internal operating instructions. The plant shall be subjected to a performance test before synchronizations. The plant shall be subjected to a performance test before synchronization under the supervision of professional engineers/consultants.

WEBEL TECHNOLOGY LIMITED

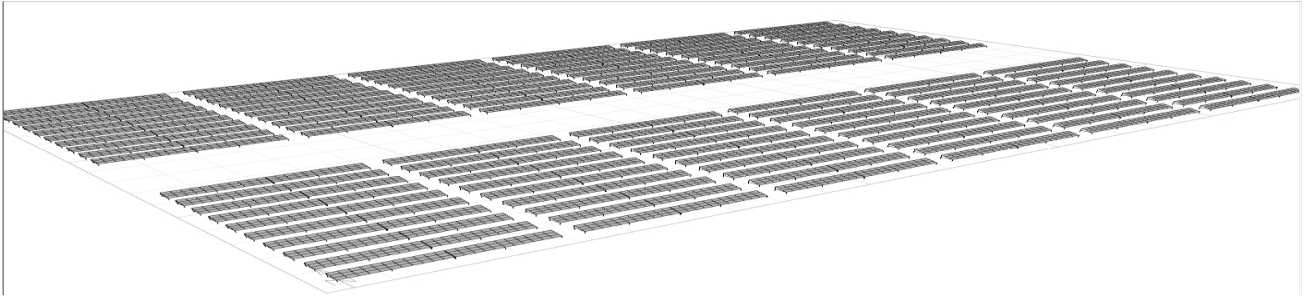

The design of the centralized configuration will start with the DC side of the power plant and then based on the DC section the AC section of the power plant is may be designed.

❖ **PROJECT MANAGEMENT AND ENGINEERING**

Vendor will provide a global expertise in designing, setting up and maintaining large scale grid connected solar farms.

Vendor shall provide the Engineering service including undertaking an engineering study to review the basic design and where possible to suggest optimized design solutions, detailed designs, etc., will also look after civil & mechanical works, equipment supplies and other contracts. Construction design and construction supervision during the execution of the project including quality assurance at site and oversee the contractors` quality systems.

Typical System Integration

The panels will be placed in roof-top only. The roof-top mounting will require a flat level surface and will be set into concrete. The panels will require an area which is not shaded. All the panels will be at least 0.8m from the ground.

The panels will be mounted in rows and electrically connected with cables. The cable will need to be made safe and tamper proof. The electrical output from the PV panels will be fed via cables to a bank of inverters.

The inverters will be housed in a structure to protect them from the weather and from tampering. A design decision based on cost will need to be made whether the inverters are all located in one area or are interspersed around the site.

The power plant will have a SCADA system to monitor the output of the rows of panels. In this way, any system faults can be detected to a particular array and rectified.

WEBEL TECHNOLOGY LIMITED

SECTION – B

ELIGIBILITY CRITERIA

1. The bidder must be a company registered under Companies Act, 1956/2013 or Partnership or LLP or Proprietary Firm and operational last 5 (Five) years as on 31st March 2025. Documentary (Certificate of incorporation/Relevant document) evidence to be submitted.
2. The bidder should have own registered office presence in Kolkata / Dinazpur District of last 5 years supporting documents to be submitted.
3. The bidder should have valid Trade License, GST Registration Number & PAN. Bidder shall have to submit photocopy of the documents.
4. The bidder should have valid PF & ESI registration certificate. Copy of the valid certificate to be submitted.
5. The bidder should have executed “Similar Nature Work” of single order an amount not less than Rs. 30.00 (Thirty Lakh) in last three financial years (FY – 2021-22, 2022-23, 2023-24) in Government Department / PSU / Autonomous Body/ any reputed organization. References order copy for the project to be provided.
6. The bidder should have average annual turnover of not less than Rs. 3.00 (Three crores) in the last three financial years (FY – 2021-22, 2022-23, 2023-24) Bidder shall have to submit Audited Balance Sheet / Audited Accounts / Auditor Certificate.
7. The bidder should have positive net worth each year in the last financial years (FY – 2023-24). Auditor Certificate to be submitted.
8. Respective OEM's shall submit NIT Declaration (Section – S) duly signed by the authorized signatory of the respective OEM as per the format. Deviation in format may not be accepted and will be considered as not eligible bid.
9. The bidder shall not have been blacklisted by any State/Central Government or PSU or bilateral/ multilateral funding agencies for breach of ethical conduct or fraudulent practices as on date of submission of the proposal (as per DIT guidance note issued on 26-Dec-2011). Declaration on bidder's letter head to be submitted.
10. The Bidder shall submit Bid Form (Section-E) duly signed by the authorised signatory of the company as per the format enclosed. Deviation in format may not be accepted.
11. Bidder shall submit NIT declaration (Section-Q) duly signed by the authorised signatory of the company as per the format. Deviation in format may not be accepted.
12. The Bidders must have valid Quality Certifications of ISO 9001:2015. Bidders to submit copies of valid Certificates.

WEBEL TECHNOLOGY LIMITED

SECTION – C

DATE AND TIME SCHEDULE

Sl. No.	Particulars	Date & Time
1	Date of uploading of N.I.T. & other Documents (online) (Publishing Date)	08.08.2025
2	Documents download/sale start date (Online)	08.08.2025
3	Last Date and time of sending the queries (to purchase@wtl.co.in)	13.08.2025at 15.00 Hrs
4	Pre Bid Meeting (Online Meeting)	14.08.2025at 12.00 Hrs
5	Corrigendum, if any will be published (On Line)	-
6	Bid Submission start date & time (On line)	19.08.2025 at 12.00 Hrs
7	Last Date & time of submission of Earnest Money Deposit & submission of remittance details	Before Uploading of Tender
8	Last Date & time of submission of Tender Fee & submission of remittance details	Before Uploading of Tender
9	Bid Submission closing date & time (On line)	22.08.2025 at 12.00 Hrs
10	Bid opening date & time for Technical Proposals (On line)	25.08.2025 at 11.00 Hrs
11	Date of uploading the final list of Technically Qualified Bidder (online) after disposal of appeals, if any	-
12	Date for opening of Financial Bid (Online)	-

WEBEL TECHNOLOGY LIMITED

SECTION – D

INSTRUCTION TO BIDDER

1. DEFINITIONS

In this document, the following terms shall have following respective meanings:

“**Acceptance Test Document**” means a document, which defines procedures for testing the functioning of installed system. The document will be finalized with the contractor with in 7 days of issuance of the Letter of Award.

“**Bidder**” means any firm offering the solution(s), service(s) and /or materials required in the RFP. The word Bidder when used in the pre award period shall be synonymous with Bidder, and when used after award of the Contract shall mean the successful Bidder.

“**Contract**” is used synonymously with Agreement.

“**Contract Price**” means the price to be paid to the Contractor for providing the Solution, in accordance with the payment terms.

“**Contractor**” means the Bidder whose bid to perform the Contract has been accepted by Tender Committee and is named as such in the Letter of Award.

“**Default Notice**” shall mean the written notice of Default of the Agreement issued by one Party to the other.

“**Installation**” shall means installation of Software.

“**Fraudulent Practice**” means a means a misrepresentation of facts in order to influence a procurement process or the execution of a Contract and includes collusive practice among Bidders (prior to or after Bid submission) designed to establish Bid prices at artificial noncompetitive levels and to deprive at Labour Department, Government of West Bengal

“**Good Industry Practice**” shall mean the exercise of that degree of skill, diligence and prudence which would reasonably and ordinarily be expected from a reasonably skilled and experienced Operator engaged in the same type of undertaking under the same or similar circumstances.

“**Government**” / “**Gov. of W. Bengal**” means the Government of West Bengal.

“**GoI**” shall stand for the Government of India.

“**GoWB**” means Government of West Bengal

“**Similar Nature of Work**” means Installation of Solar Panel Work or any project that requires usage of Solar panels.

“**Project**” means Installation of Grid-Connected Rooftop Solar Panel at Dakshin Dinajpur Zilla Parishad office Building, Government of West Bengal.

“**Services**” means the work to be performed by the Bidder pursuant to this Contract, as described in the detailed Scope of Work.

“**Interest rate**” means “364 days Government of India (GoI) Treasury Bills” rate.

“**Law**” shall mean any Act, notification, by law, rules and regulations, directive, ordinance, order or instruction having the force of law enacted or issued by the Central Government and/or the Government of West Bengal or any other Government or regulatory authority or political subdivision of government agency.

“**LOI**” means issuing of Letter of Intent shall constitute the intention of the WTL to place the Purchase Order with the successful bidder.

WEBEL TECHNOLOGY LIMITED

"Operator" means the company providing the services under Agreement.

"Requirements" shall mean and include schedules, details, description, statement of technical data, performance characteristics, standards (Indian as well as International) as applicable and specified in the Contract.

"DDZP" means Dakshin Dinajpur Zilla Parishad

"Service" means provision of Contracted service viz., development operation, maintenance and associated services as per Section titled "Scope of Work"

"Termination Notice" means the written notice of termination of the Agreement issued by WTL.

"Uptime" means the time period when specified services are available with specified technical and service standards as mentioned in section titled WARRANTY SUPPORT" "%Uptime" means ratio of 'up time' (in minutes) as mentioned in section titled "Warranty support"

"Service Down Time" (SDT) means the time period when specified services with specified technical and operational requirements as mentioned in section titled "WARRANTY SUPPORT" are not available to Gov. of W. Bengal and its user departments and organizations.

"WTL" means Webel Technology Limited a Govt. of W. Bengal undertaking.

2. PRE BUD MEETING

Pre Bid Meeting will be held on 14.08.2025 at 12.00 Hrs (On Line Meeting). Bidder can see their queries as per format (Section-R) to Purchase Department (purchase@wtl.co.in). Only the queries received within the stipulated date prior to the Pre Bid Meeting will be answered. Queries to be sent in XL Format. Interest bidders are requested to send mail to (purchase@wtl.co.in) for participating of online pre-bid meeting based on request WTL will share meeting id/links for meeting. Participants will be informed of changes in schedule if any.

3. COST OF BIDDING

The bidder shall bear all costs associated with the preparation and submission of the bid and WTL will not be responsible for those costs regardless of the conduct or outcome of the bidding process.

4. BID DOCUMENT

Bidder is expected to examine all instructions, forms, terms and requirement in the bid document. The invitation to bid together with all its attachment thereto shall be considered to be read, understood and accepted by the bidder unless deviations are specifically stated in the seriatim by the bidder. Failure to furnish all information required by the bid document or a bid not substantially responsive to the bid document in every respect may result of the bid.

5. AMENDMENT OF BID DOCUMENT

At any time prior to the deadline for submission of proposals, WTL reserves the right to add/modify/delete any portion of this document by issuance of an Corrigendum, which would be published on the website and will also be made available to the all the Bidder who have been issued the tender document. The Corrigendum shall be binding on all bidders and will form part of the bid documents.

6. MODIFICATION AND WITHDRAWAL OF BIDS

As per the bidding process available in the tender. The bidder cannot modify or withdraw its bid after submission.

7. LANGUAGE OF BID & CORRESPONDENCE

The proposal will be prepared by the Bidder in English language only. All the documents relating to the proposal (including brochures) supplied by the firm should also be in English, and the correspondence between the Bidder & WTL will be in English language only. The correspondence by fax/E-mail must be subsequently confirmed by a duly signed formal copy.

WEBEL TECHNOLOGY LIMITED

8. BIDDER'S SOLUTION

The bidders are requested to study the Bill of Material supplied with this document carefully. While working out the solution the bidder has to work with the broad minimum specification provided in the tender documents, conforming to the model, make and Part number (wherever provided). While submitting the bid the bidder has to detail out all components needed to complete the system BOM. The bidder is required quote for each item retaining all major components/sub system detailed and specified. As the contractor will be responsible for smooth functioning of the system, availability of spares during the tenure of the warranty period have to be take care by the contractor to maintain the guaranteed uptime.

9. EARNEST MONEY DEPOSIT (EMD) / TENDER FEE

The bidder shall furnish Online Receipt against payment of Tender Fees and Earnest Money Deposit

10. REFUND OF EMD

EMD will be refunded to the unsuccessful bidders without interest by following guidelines of circular 3975-F(Y) dated 28/07/2016 on final selection of Successful Bidders.

11. FORFEITURE OF EMD

EMD made by Bidder may be forfeited under the following conditions:

If Bidder withdraws the proposal before the expiry of validity period.

During the evaluation process, if a Bidder indulges in any such activity as would jeopardize the process, the decision of WTL regarding forfeiture of EMD shall be final and shall not be called upon question under any circumstances.

If Bidder violates any of the provisions of the terms and conditions of the proposal.

In the case of a successful Bidder, if Bidder fails to:

- a) Accept the work order along with the terms and conditions.
- b) Furnish performance security.
- c) Violates any of the work conditions of this proposal or indulges in any such activities as would jeopardize the work.
- d) Submitting false/misleading information/declaration/documents/proof/etc.

The decision of WTL regarding forfeiture of EMD shall be final and shall not be called upon to question under any circumstances, besides, forfeiture of EMD even the Bidder will be deferred from participating in any job for a period of one year.

12. FORMS AND FORMATS

The various inputs for the Techno Commercial as Financial Bids are to be submitted in the format specified. The bidder shall use the form, wherever specified, to provide relevant information. If form does not provide space for any required information, space at the end of the form or additional sheets shall be used to convey the said information. For all other cases, the bidder shall design a form to hold the required information.

13. LACK OF INFORMATION TO BIDDER

The bidder shall be deemed to have carefully examined the Bid document to his entire satisfaction. Any lack of information shall not relieve the bidder of his responsibility to fulfill his obligation under the bid. If bidder has any queries relating to bid document then he can send the queries before the Pre Bid Meeting.

14. CONTRACT EXECUTION

On receipt of the Letter of Award the contractor should submit a Performance Bank Guarantee (PBG) equivalent to 10% of the total contract value within three weeks from the date of receipt of Letter of Award/Order. The PBG should be valid for six month more than the warranty period. All delivery of the material will have to be completed within 45 days from the date of acceptance of contract and the contractor has to ensure all activities leading to the commissioning of the contract to be completed within

WEBEL TECHNOLOGY LIMITED

75 days from the date of award. Subsequent to the award of contract, the contractor will have to arrange for the requisite material as per BOM.

15. TIME SCHEDULE FOR DELIVERY

Within 7 (Seven) weeks from the date of receiving final order from WTL.

16. LIQUIDATED DAMAGE / PENALTY

The job includes the supply and installation of materials mentioned in the tender document. In the event of failure to meet the job completion in stipulated date/time liquidated damage may be imposed on the contractor for sum not less than 0.5% of the contract value for that item/job for each week or part thereof, subject to a ceiling of 10% of the total contract value (excluding all taxes & duties and other charges). In the event of LD exceeds 10% of the order value, WTL reserves the right to terminate the contract and WTL will get the job completed by any other competent party. The difference of cost incurred by WTL will be recovered from the contractor and PBG will be invoked.

17. LIABILITY

In case of a default on bidder's part or other liability, WTL shall be entitled to recover damages from the Contractor. In each such instance, regardless of the basis on which WTL is entitled to claim damages from the Contractor (including fundamental breach, negligence, misrepresentation, or other contract or tort claim), Contractor shall be liable for no more than:

- Payment referred to in the Patents and Copyrights clause.
- Liability for bodily injury (including death) or damage to real property and tangible personal property limited to that cause by the Contractor's negligence.
- As to any other actual damage arising in any situation involving non-performance by Contractor pursuant to or in any way related to the subject of this Agreement, the charge paid by WTL for the individual product or Service that is the subject of the Claim. However, the contractor shall not be liable for
- For any indirect, consequential loss or damage, lost profits, third party loss or damage to property or loss of or damage to data.
- For any direct loss or damage that exceeds the total payment for Contract Price made or expected to be made to the Contractor hereunder.

18. PATENTS & COPYRIGHT

If a third party claims that a product delivered by the Contractor to WTL infringes that party's patent or copyright, the Contractor shall defend WTL against that claim at Contractor's expense and pay all costs, damages, and attorney's fees that a court finally awards or that are included in a settlement approved by the Contractor, provided that WTL.

- Promptly notifies Contractor in writing of the claim
- Allows Contractor to control and co-operate with Contractor in the defense and any related settlement negotiations.

Remedies: If such a claim is made or appears likely to be made, WTL would permit Contractor to enable WTL to continue to use the product, or to modify it, or replace it with one that is at least functionally equivalent. If Contractor determines that none of these alternatives is reasonably available, WTL agrees to return the product to Contractor on Contractor's written request. Contractor will then give WTL a credit equal to for a machine. WTL's net book value (provided WTL has followed generally accepted accounting principles for a generally available software product produced by Contractor (Program) the amount paid by WTL or 12 months charges (which ever is lesser) and for materials the amount paid by WTL for the materials. These will be Contractor's entire obligation regarding any claim of infringement.

19. SUSPENSION OF WORK

WTL shall have the power at any time and from time to time by notice to the Contractor to delay or suspend the progress of the work or any part of the work due to any other adequate reasons and on receipt of such notice the contractor shall forthwith suspend further progress of the work until further notice from WTL. The Contractor shall recommence work immediately after receiving a notice to do so from WTL. The whole or any part of the time lost for such delay or suspension shall, if WTL in its absolute discretion thinks fit, but not otherwise, be added to the time allowed for completion.

20. TERMS OF PAYMENT

Payment terms will be on back-to-back basis, i.e., payment will be made only on receipt of payment from relevant customer, i.e, Dakshin Dinajpur Zilla Parishad, GoWB

WEBEL TECHNOLOGY LIMITED

21. GOVERNING LAWS

This contract should be governed by and interpreted by Arbitration clause in accordance with Laws in force in India. The courts at Kolkata shall have exclusive jurisdiction in all matters arising under the contract. The selected vendor shall keep himself fully informed of all current national, state and municipal law and ordinances. The selected vendor shall at their own expense, obtain all necessary permits and license and pay all fees and taxes required by law. These will be selected vendor's entire obligation regarding any claim of infringement. The selected vendor hereto agrees that it shall comply with all applicable union, state and local laws, ordinances, regulations and codes in performing its obligations hereunder, including the procurement of licenses, permits certificates and payment of taxes where required. The selected vendor shall establish and maintain all proper records (particularly, but without limitation, accounting records) required by any law, code/practice of corporate policy applicable to it from time to time including records and returns as applicable under labor legislation.

22. CORRUPT OR FRAUDULENT

The Tender Committee requires that the bidders under this Tender observe the highest standards of ethics during the procurement and execution of such contracts. For this purpose the definition of corrupt and fraudulent practices will follow the provisions of the relevant laws in force. The Tender Committee will reject a proposal for award if it detects that the bidder has engaged in corrupt or fraudulent practices in competing for the contract in question. The Tender Committee will declare a firm ineligible, either indefinitely or for a stated period of time, if it at any time determines that the firm has engaged in corrupt and fraudulent practices in competing for, or in executing, a contract.

23. BIDDING CLAUSE

All decisions taken by the Tender Committee regarding the processing of this tender and award of contract shall be final and binding on all parties concerned.

The Tender Committee reserves the right:

- To vary, modify, revise, amend or change any of the terms and conditions mentioned above and,
- To reject any or all the Tender/s without assigning any reason whatsoever thereof or to annul the bidding process and reject all bids at any time prior to award of contract, without thereby incurring any liability to the affected bidder(s) or any obligation to inform the affected bidder(s) of the grounds for such decision.

24. WORKMEN'S COMPENSATION

In every case in which by virtue of the provision of the workmen's compensation Act 1923 or any other relevant acts and rules, compensation to a workmen employed by the contractor, is payable, then this should be done by the Contractor. If WTL is obliged to make any compensation under the said rules and acts, then the amount shall be recovered without prejudice, from the bills and due of the Contractor. WTL shall not be bound to contest any claim made against the Contractor in respect of workmen's compensation.

25. CONTRACTOR'S EMPLOYEES

The Contractor shall comply with the provision of all labour legislation including the requirement of the payment of Wage Act 1936 and the rules framed there under and modifications thereof in respect of men employed by him in carrying out the contract. The Contractor must ensure that he complies with PF, ESI regulation for all his deployed employees. The Contractor shall see that all authorized Sub Contractors under him similarly complied with the above requirement.

26. SAFETY MEASURES

The Contractor shall in the course of execution of the work take all necessary precaution for the protection of all persons and property. The Contractor shall take adequate measures to protect the work and present accident during the work. In the event of any accident to any person or persons or damage or injury of any description to any person or property due to failure on the part of the contractor in taking proper precautionary measures the contractor shall be responsible for and must make good the loss the damage at his own cost to the satisfaction of the department and employees of the department shall be indemnified from all claims or liabilities arising there from or any expenses incurred on account thereof.

27. EQUIPMENT

All tools & tackles necessary for the work shall have to be procured by the contractor unless other wise specified elsewhere in these tender documents. The equipment used by the contractor for a particular

WEBEL TECHNOLOGY LIMITED

work must be appropriate for the type of work. The contractor shall maintain the equipment used on the work properly so that they are in good working condition. In no case shall the contractor use defective or imperfect equipment in the work. The contractor shall arrange to replace or repair all defective equipment so that the progress of the work is not hampered. No defective equipment should be left at the site of work and the department shall not be responsible for any loss or damage to any of these equipments during the course of the execution of the work.

28. SUB-CONTRACT

The purchaser (WTL) does not recognize the existence of Sub-Contractors. The Contractor's responsibility is not transferable. No consortium partner is allowed.

29. TERMINATION FOR DEFAULT

WTL may without prejudice to any other remedy or right of claim for breach of contract by giving not less than 30 days written notice of default sent to the contractor, terminate the order in whole or in part. If the contractor materially fails to render any or all the services within the time period specified in the contract or any extension thereof granted by WTL in writing and fails to remedy its failure within a period of thirty days after receipt of default notice from WTL. If the project (delivery, commissioning as well as warranty maintenance support is not carried out according to specification due to deficiency in service as per terms of the contract. In such case WTL will invoke the amount held back from the contractor as PBG.

30. BANKRUPTCY

If the contractor becomes bankrupt or have a receiving order made against him or compound with his creditors or being a corporation commence to be wound up, not being a voluntary winding up for the purpose only or amalgamation or reconstruction, or carry on their business under a receiver for the benefit of their creditors or any of them, WTL shall be at liberty to terminate the engagement forthwith without any notice in writing to the contractor or to the liquidator or receiver or to any person in whom the contractor may become vested and without any compensation to give such liquidator or receiver or other person the option of carrying out the engagement subject to their providing a guarantee for the due and faithful performance of the engagement up to an amount to be determined by WTL.

31. FORCE MAJEURE

It is hereby defined as any cause, which is beyond the control of the Contractor or WTL as the case may be, which such party could not foresee or with a reasonable amount of diligence could not have foreseen and which substantially affect the performance of the contract, such as

- War, Hostilities or warlike operations (whether a state of war be declared or not), invasion, act of foreign enemy and civil war.
- Rebellion, revolution, insurrection, mutiny, usurpation of civil or military, government, conspiracy, riot, civil commotion and terrorist area.
- Confiscation, nationalization, mobilization, commandeering or requisition by or under the order of any government or de facto authority or ruler, or any other act or failure to act of any local state or national government authority.
- Strike, sabotage, lockout, embargo, import restriction, port congestion, lack of usual means of public transportation and communication, industrial dispute, shipwreck, shortage of power supply epidemics, quarantine and plague.
- Earthquake, landslide, volcanic activity, fire flood or inundation, tidal wave, typhoon or cyclone, hurricane, nuclear and pressure waves or other natural or physical disaster.

If either party is prevented, hindered or delayed from or in performing any of its obligations under the Contract by an event of Force Majeure, then it shall notify the other in writing of the occurrence of such event and the circumstances of the event of Force Majeure within fourteen days after the occurrence of such event. The party who has given such notice shall be excused from the performance or punctual performance of its obligations under the Contract for so long as the relevant event of Force Majeure continues and to the extent that such party's performance is prevented, hindered or delayed.

The party or parties affected by the event of Force Majeure shall use reasonable efforts to mitigate the effect of the event of Force Majeure upto its or their performance of the Contract and to fulfill its or their obligation under the Contract but without prejudice to either party's right to terminate the Contract.

No delay or nonperformance by either party to this Contract caused by the occurrence of any event of Force Majeure shall.

WEBEL TECHNOLOGY LIMITED

- Constitute a default or breach of the contract.
- Give rise to any claim for damages or additional cost or expense occurred by the delay or nonperformance. If, and to the extent, that such delay or nonperformance is caused by the occurrence of an event of Force Majeure.

32. INSURANCE COVERAGE

Appropriate insurance to cover all solution components for the transit period and until the time of its acceptance at the respective site is to be taken by the contractor. As the contractor will carry the risk for the material in his books during transit, the contractor should arrange insurance for the total system as period from the dispatch till Acceptance Test is successfully achieved. Further the contractor is to take all required insurance coverage in respect of all its personnel who shall be working on this engagement.

33. WARRANTY

The OEM on behalf of bidder will warranty that product supplied under the contract are newly made and are free from defects in the design, engineering and workmanship. The Contractor would be responsible for the up keep and maintenance of the Solar PV, Inverter and necessary deliverables under the scope of work during the entire warranty period, i.e., Solar PV 25 (Twenty-Five) years and Inverter and necessary deliverables 5 (Five) years for from the date of final acceptance of the system by the user. Within warranty period, entrusted OEM will replace, re-integrate faulty, buggy components. The Contractor/OEM shall not, without the express prior written consent of WTL, assign to any third party of the contract or part thereof. Service support for the entire warranty period will be on site and comprehensive (including spares) and free of cost for the entire warranty period. Warranty will be invalid if the equipment is serviced by unauthorized personnel of misuse is detected.

34. WARRANTY SUPPORT & SLA

As per Section - P

35. PERFORMANCE BANK GUARANTEE (PBG)

As a guarantee for timely delivery, installation and commissioning of equipment as well as performance of on-site warranty support, as mentioned in Bill of Material, from the date of final acceptance of systems and pertaining to proper running of the systems, the bidder will have to submit 10% of the contract value as security in the form of Performance Bank Guarantee from any nationalized bank as per format enclosed (Section – O).

36. SI/BIDDER/CONTRACTOR'S RESPONSIBILITIES

Refer Section – A (Scope of Work & Responsibility)

37. NO WAIVER OF RIGHTS

Neither the inspection by WTL or any of their agents nor any order by WTL for payment of money or any payment for or acceptance of the whole or any part of the works by WTL, nor any extension of time, nor any possession taken by WTL shall operate as a waiver of any provision of the contract or of any power reserved to WTL, or any right to damages here in provided, nor shall any waiver of any breach in the contract be held to be a waiver of any other subsequent breach.

38. GRAFTS, COMMISSIONS, GIFTS, ETC.

It is the Purchaser's policy to require that bidders, suppliers, contractors and consultants under contracts, observe the highest standard of ethics during the procurement and execution of such contracts. Any graft, commission, gift or advantage given, promised or offered by or on behalf of the contractor or his partner, agent, officers, director, employee or servant or any one on his or their behalf in relation to the obtaining or to the execution of this or any other contract with WTL shall in addition to any criminal liability which it may incur, subject the contractor to the cancellation of this and all other contracts and also to payment of any loss or damage to WTL resulting from any cancellation. WTL shall then be entitled to deduct the amount so payable from any monies otherwise due to the contractor under contract.

39. ENFORCEMENT OF TERMS

The failure of either party to enforce at any time any of the provision of this contract or any rights in respect thereto or to exercise any option here in provided shall in no way be construed to be a waiver to such provisions, rights or options or in any way to affect the validity of the contract. The exercise by either party of any of its rights herein shall not preclude or prejudice either party from exercising the same or any other right it may have hereunder.

WEBEL TECHNOLOGY LIMITED

40. PERIOD OF VALIDITY OF OFFER

For the purpose of placing the order, the proposals shall remain valid till 180 days. During the period of validity of proposals, the rates quoted shall not change. In exceptional circumstances, WTL may ask for extension of the period of validity and such a request shall be binding on Bidders. WTL's request and the response to such a request by various Bidders shall be in writing. A Bidder agreeing to such an extension will not be permitted to increase its rates.

41. TAXES & DUTIES

- The prices shall be inclusive of all taxes & levies including GST and other statutory duties as applicable. Rate of taxes should be indicated separately in the Price Bid.
- Contract Price specified in Price Bid should be based on the taxes & duties and charges prevailing at the date one day prior to the last date of Bid submission.
- Statutory deduction, wherever applicable, shall be made from invoice as per government rules. Necessary certificate will be issued for such deductions.
- Bidder submitting a bid shall produce valid statutory documents / certificates with respect to GST, Income Tax, ROC, Prof. Tax, Trade Licence, etc. All such documents / certificates shall remain valid on the last date of tender submission.
- In case of inter-state transaction, WTL will provide "Waybill". However, statutory charges, if any will be borne by the bidder.
- GST component of the invoice of the bidder may be kept on hold in case there is any mismatch / irregularity in GST return filing on the part of the bidder.

42. DISCREPANCIES IN BID

- Discrepancy between description in words and figures, the rate which corresponds to the words quoted by the bidder shall be taken as correct.
- Discrepancy in the amount quoted by the bidder due to calculation mistake of the unit rate then the unit rate shall be regarded as firm.
- Discrepancy in totaling or carry forward in the amount quoted by the bidder shall be corrected.

43. BID DUE DATE

The online tender has to be submitted not later than the due date and time specified in the Important Dates Sheet. WTL may at its discretion on giving reasonable notice by fax, or any other written communication to all prospective bidders who have been issued the bid documents, extend the bid due date, in which case all rights and obligations of the WTL and the bidders, previously subject to the bid due date, shall thereafter be subject to the new bid due date as extended.

44. OPENING OF BID BY WTL

Bids shall be opened and downloaded electronically through operation of the process in the e-Tender portal in presence of Tender Committee. Bidders interested to remain present during electronic bid opening may attend the bid opening session at WTL premises at scheduled date & time.

45. CONTACTING WTL

Bidder shall not approach WTL officers beyond office hours and/or outside WTL office premises from the time of the Bid opening to the time of finalization of successful bidder. Any effort by bidder to influence WTL office in the decision on Bid evaluation, Bid comparison or finalization may result in rejection of the Bidder's offer. If the bidder wishes to bring additional information to the notice of WTL, it should be in writing following the procedure mentioned hereinabove.

46. WTL'S RIGHT TO REJECT ANY OR ALL BIDS

WTL reserves the right to reject any bid and to annul the bidding process and reject all bids at any time prior to award of Contract, without thereby incurring any liability to the affected bidder(s) or any obligation to inform the affected bidder(s) of the grounds for such decision.

47. BID CURRENCIES

Prices shall be quoted in Indian Rupees, inclusive of all prevailing GST, levies, duties, cess etc.

48. PRICE

WEBEL TECHNOLOGY LIMITED

- Price should be quoted in the Price Bid format only. No deviation in any form in the Price Bid sheet is acceptable.
- Price quoted should be firm, inclusive of packing, forwarding, insurance and freight charges.
- Percentage/specified amount of taxes & duties should be clearly mentioned otherwise WTL reserves the right to reject such vague offer.
- Price to be quoted inclusive of supply, installation & commissioning charges.

49. CANVASSING

Canvassing or support in any form for the acceptance of any tender is strictly prohibited. Any bidder doing so will render him liable to penalties, which may include removal of this name from the register of approved Contractors.

50. NON-TRANSFERABILITY OF TENDER

This tender document is not transferable.

51. FORMATS AND SIGNING OF BID

The original and all copies of the proposals shall be neatly typed and shall be signed by an authorized signatory(ies) on behalf of the Bidder. The authorization shall be provided by written Power of Attorney accompanying the proposal. All pages of the proposal, except for un-amended printed literature, shall be initialed by the person or persons signing the proposal. The proposal shall contain no interlineations, erase or overwriting. In order to correct errors made by the Bidder, all corrections shall be done & initialed with date by the authorized signatory after striking out the original words/figures completely.

52. WITHDRAWAL OF BID

Bid cannot be withdrawn during the interval between their submission and expiry of Bid's validity period. Fresh Bid may be called from eligible bidders for any additional item(s) of work not mentioned herein, if so required.

53. INTERPRETATION OF DOCUMENTS

If any bidder should find discrepancies or omission in the specifications or other tender documents, or if he should be in doubt as to the true meaning of any part thereof, he shall make a written request to the tender inviting authority for correction/clarification or interpretation or can put in a separate sheet along with his technical bid document.

54. SPLITTING OF THE CONTRACT AND CURTAILMENT OF WORK

WTL reserve the right to split up and distribute the work among the successful bidders and to curtail any item of work in the schedule partly or fully.

55. PREPARATION OF TENDER

Tender shall be submitted in accordance with the following instructions:

- a) Tenders shall be submitted in the prescribed forms. Digital signatures shall be used. Where there is conflict between the words and the figures, the words shall govern.
- b) All notations must be in ink or type written. No erasing or overwriting will be permitted. Mistakes may be crossed out and corrections typed or written with ink adjacent thereto and must be initialed in ink by the person or persons signing the tender.
- c) Tenders shall not contain any recapitulation of the work to be done. Alternative proposals will not be considered unless called for. No written, oral, telegraphic or telephonic proposals for modifications will be acceptable.
- d) Tenders shall be uploaded as notified on or before the date and time set for the opening of tenders in the Notice Inviting Tenders.
- e) Tenders subject to any conditions or stipulations imposed by the bidder are liable to be rejected.
- f) Each and every page of the tender document must be signed with company seal by the bidder.
- g) Any bidder may withdraw his tender by written request at any time prior to the scheduled closing time for receipt of tenders and not thereafter.

56. PRE-DISPATCH INSTRUCTION

All materials / equipments supplied against the purchase order shall be subjected to Inspection, check and /or test by the authorized representative from WTL.

WEBEL TECHNOLOGY LIMITED

57. FINAL INSPECTION

Final inspection will be carried by the authorized representative from WTL.

58. SITE INSPECTION

Bidder can inspect (at their own cost) the sites if required, for which they have to take necessary permission from WTL in writing. WTL will take at least four days to organize such permission.

59. ERASURES OR ALTERNATIONS

The offers with overwriting and erasures may make the tender liable for rejection if each of such overwriting/erasures/manuscript ions is not only signed by the authorized signatory of the bidder. There should be no hand-written material, corrections or alterations in the offer. Technical details must be completely filled up. Correct technical information of the product being offered must be filled in. Filling up of the information using terms such as "OK", "accepted", "noted", "as given in brochure/manual" is not acceptable. The Customer may treat offers not adhering to these guidelines as unacceptable. The Customer may, at its discretion, waive any minor non-conformity or any minor irregularity in the offer. This shall be binding on all bidders and the Tender Committee reserves the right for such waivers.

60. COMPLIANCE WITH LAW

The contractor hereto agrees that it shall comply with all applicable union, state and local laws, ordinances, regulations and codes in performing its obligations hereunder, including the procurement of licenses, permits certificates and payment of taxes where required. The contractor shall establish and maintain all proper records (particularly, but without limitation, accounting records) required by any law, code/practice of corporate policy applicable to it from time to time including records and returns as applicable under labor legislation.

61. CLARIFICATION OF BIDS

During evaluation of the bids, the Customer/Tender Committee, at its discretion may ask the bidder for clarification of its bid. The request for the clarification and the response shall be in writing (fax/email) and no change in the substance of the bid shall seek offered or permitted.

62. DEEMED ACCEPTANCE

Deliverables will be deemed to be fully and finally accepted by the Labour Department, GoWB has not submitted such Deliverable Review Statement to Bidder/Implementation Partner before the expiration of the 30-days review period, or when the Labour Department uses the Deliverable in its business, whichever occurs earlier ("Deemed Acceptance").

63. QUALITY CONTROL

- The contractor is obliged to work closely with WTL, act within its authority and abide by directive issued by them on implementation activities.
- The contractor will abide by the safety measures and free WTL from all demands or responsibilities arising from accident/loss of life, the cause of which is due to their negligence. The bidder will pay all indemnities arising from such incidents and will not hold WTL responsible.
- The contractor will treat as confidential all data and information about the system, obtained in the execution of its responsibilities in strict confidence and will not reveal such information to any party without the prior written approval of WTL.
- WTL reserves the right to inspect all phases of contractor's operation to ensure conformity to the specifications. WTL shall have engineers, inspectors or other duly authorized representatives made known to the contractor, present during the progress of the work and such representatives shall have free access to the work at all times. The presence or absence of representatives of WTL does not relieve the contractor of the responsibility for quality control in all phases.
- The Court of Kolkata only will have the jurisdiction to deal with and decide any legal matters or dispute whatsoever arising out of the contract.

64. SITE NOT READY

The bidder shall not be in any manner liable for any delay arising out of WBSBCL inability to make the site ready within the stipulated period.

WEBEL TECHNOLOGY LIMITED

65. GENERAL TERMS

- a) All the pages of the bid document including documents submitted therein must be duly signed and stamped failing which the offer shall be liable to be rejected.
- b) All the documents to be submitted by the bidder along with their offer should be duly authenticated by the person signing the offer and if at any point of time during procurement process or subsequently it is detected that documents submitted are forged/tampered/manipulated in any way, the total responsibility lies with the bidder and WTL reserves the full right to take action as may be deemed fit including rejection of the offer and such case is to be kept recorded for any future dealing with them.
- c) No Technical/Commercial clarification will be entertained after opening of the tender.
- d) Overwriting and erasures may make the tender liable for rejection if each of such overwriting/erasures/manuscription is not only signed by the authorized signatory of the bidder. All overwriting should be separately written and signed by the authorized signatory of the bidder.
- e) Quantity mentioned in the tender document is indicative only and orders shall be placed subject to actual requirement. WTL reserve the right to increase or decrease the quantity specified in the tender.
- f) WTL reserve the right to reject or accept or withdraw the tender in full or part as the case may be without assigning the reasons thereof. No dispute of any kind can be raised the right of buyer in any court of law or elsewhere.
- g) WTL reserve the right to ask for clarification in the bid documents submitted by the bidder. Documents may be taken if decided by the committee.
- h) Supporting technical brochures / catalogues indicating each feature in respect of offered model and make must be submitted along with the offer, in absence of which the offer is liable to be ignored.
- i) No dispute by the bidders in regard to Technical/Commercial points will be entertained by WTL and decision taken by the Tender Committee will be final.
- j) Discrepancy in the amount quoted by the bidder due to calculation mistake, the unit rate shall be regarded as firm and the totaling or carry in the amount quoted by the bidder shall be corrected accordingly.
- k) The price offers shall remain firm within the currency of contract and no escalation of price will be allowed.
- l) The acceptance of the tender will rest with the accepting authority who is not bound to accept the lowest or any tender and reserves the right to reject in part or in full any or all tender(s) received and to split up the work among participants without assigning any reason thereof.
- m) The customer/WTL at its discretion may extend the deadline for the submission of Bids.
- n) The Court of Kolkata only will have the jurisdiction to deal with and decide any legal matters or dispute whatsoever arising out of the contract.

WEBEL TECHNOLOGY LIMITED

SECTION – E

BID FORM

(Bidders are requested to furnish the Bid Form in the Format given in this section, filling the entire Blank and to be submitted on Letter Head in original)

To
Webel Technology Limited
Plot – 5, Block – BP, Sector - V,
Salt Lake City,
Kolkata – 700091.

Sub: Installation of Grid-Connected Rooftop Solar Panel at Dakshin Dinajpur Zilla Parishad office Building, Government of West Bengal.

Dear Sir,

1. We the undersigned bidder/(s), having read and examined in details the specifications and other documents of the subject Tender No. WTL/DDZP/SOLAR/25-26/017 dated 08.08.2025, do hereby propose to execute the job as per specification as set forth in your Bid documents.
2. The prices of all items stated in the bid are firm during the entire period of job irrespective of date of completion and not subject to any price adjusted as per in line with the bidding documents. All prices and other terms & conditions of this proposal are valid for a period of 180 (one hundred eighty) days from the date of opening of bid. We further declare that prices stated in our proposal are in accordance with your bidding.
3. We confirm that our bid prices include all other taxes and duties and levies applicable on bought out components, materials, equipments and other items and confirm that any such taxes, duties and levies additionally payable shall be to our account.
4. Earnest Money Deposit & Tender Fee: We have transferred EMD & Tender Fee amount online through e-Tender Portal.
5. We declare that items shall be executed strictly in accordance with the specifications and documents irrespective of whatever has been stated to the contrary anywhere else in our proposal. Further, we agree that additional conditions, deviations, if any, found in the proposal documents other than those stated in our deviation schedule, save that pertaining to any rebates offered shall not be given effect to.
6. If this proposal is accepted by you, we agree to provide services and complete the entire work, in accordance with schedule indicated in the proposal. We fully understand that the work completion schedule stipulated in the proposal is the essence of the job, if awarded.
7. We further agree that if our proposal is accepted, we shall provide a Performance Bank Guarantee of the value equivalent to ten percent (10%) of the Order value as stipulated in Financial Bid (BOQ).
8. We agree that WTL reserves the right to accept in full/part or reject any or all the bids received or split order within successful bidders without any explanation to bidders and his decision on the subject will be final and binding on Bidder.

WEBEL TECHNOLOGY LIMITED

Dated, thisday of2025

Thanking you, we remain,

Yours faithfully

.....
Signature

.....
Name in full

.....
Designation

Signature & Authorized Verified by

.....
Signature

.....
Name in full

.....
Designation

.....
Company Stamp

WEBEL TECHNOLOGY LIMITED

SECTION – F

TECHNO COMMERCIAL EVALUATION & AWARDING OF CONTRACT

1. EVALUATION PROCEDURE

- The Eligibility Criteria (Section - B) will be evaluated by Tender Committee and only those qualifying with required supporting documents will be considered for further evaluation.
- The Tender Committee shall verify the Technical Specification (Technical Specification with Compliance Statement, Section – I) Deviation in specification shall not be allowed. Only Bidders qualified in Technical Specification shall be considered for further evaluation.
- After qualifying in Technical Specification, qualified bidders will only be considered for Financial Bid evaluation.

2. FINAL EVALUATION

Financial Proposal of the bidders qualifying in the evaluation of Eligibility Criteria & Technical Evaluation will be evaluated. The bidder who has qualified in the Eligibility Criteria & Technical Evaluation and returns with lowest quote (L1) in financial bid would normally be awarded the contract subject to Post Qualification.

3. AWARDING OF CONTRACT

An affirmative Post Qualification determination will be prerequisite for award of the contract to the lowest quoted bidder. A negative determination will result in rejection of bidder's bid, in which event the WTL will proceed to the next lowest evaluated bidder to make a similar determination of that bidder's capability to perform satisfactorily. The successful bidder (s) will have to give security deposit in the form of Performance Bank Guarantee.

4. POST QUALIFICATION

The determination will evaluate the Bidder's financial, technical, design, integration, customization, production, management and support capabilities and will be based on an examination of the documentary evidence of the Bidder's qualification, as well as other information WTL deems necessary and appropriate. This determination may include visits or interviews with the Bidder's client's reference in its bid, site inspection, and any other measures. At the time of post-qualification, Directorate of may also carry out tests to determine that the performance or functionality of the Information System offered meets those stated in the detailed Scope of Work.

WEBEL TECHNOLOGY LIMITED

SECTION – G

GUIDANCE FOR E-TENDERING

Instructions / Guidelines for electronic submission of the tenders have been annexed for assisting the Bidders to participate in e-Tendering.

- **Registration of Bidder:**
Any Bidder willing to take part in the process of e-Tendering will have to be enrolled & registered with the Government e-Procurement System through logging on to <https://wbtenders.gov.in>. The Bidder is to click on the link for e-Tendering site as given on the web portal.
- **Digital Signature Certificate (DSC):**
Each Bidder is required to obtain a Class-II or Class-III Digital Signature Certificate (DSC) for submission of tenders from the approved service provider of the National Informatics Centre (NIC) on payment of requisite amount. Details are available at the Web Site stated above. DSC is given as a USB e-Token.
- The Bidder can search & download N.I.T. & BOQ electronically from computer once he logs on to the website mentioned above using the Digital Signature Certificate. This is the only mode of collection of Tender Documents.
- **Participation in more than one work:**
A prospective bidder shall be allowed to participate in the job either in the capacity of individual or as a partner of a firm. If, found to be applied severally in a single job all the applications will be rejected.
- **Submission of Tenders:**
Tenders are to be submitted through online to the website stated above in two folders at a time, one in Techno Commercial Proposal & the other is Financial Proposal before the prescribed date & time using the Digital Signature Certificate (DSC). The documents are to be uploaded virus scanned copy duly Digitally Signed. The documents will get encrypted (transformed into non readable formats)

The proposal should contain scanned copies of the following in two covers (folders).

Techno Commercial Cover:

Technical Document 1 (scanned & join in pdf format then upload)

1. NIT Declaration duly stamped & signed in letter head of bidder (Section – Q)
2. Other Documents

Technical Document 2 (scanned & join in pdf format then upload)

1. Bid Form as per format (Section – E)
2. Manufacturer's Authorization Form (Section – S)
3. Other Documents

Financial Cover:

BOQ will be downloaded and same will be uploaded with quoted rates. While uploading BOQ file name shall remain unchanged. Absence of this document shall lead to summary rejection of the bid.

WEBEL TECHNOLOGY LIMITED

NON-STATUTORY COVER (MY SPACE) CONTAIN FOLLOWING DOCUMENT:

(In each folder, scanned copy will be uploaded with single file having multiple pages)

Sl. No.	Category Name	Sub Category Name	Sub Category Description
A	CERTIFICATES	A1. CERTIFICATES	<ul style="list-style-type: none"> • GST Registration Certificate • PAN • Trade License • As required
B	COMPANY DETAILS	B1. COMPANY DETAILS 1	<ul style="list-style-type: none"> • As required
		B2. COMPANY DETAILS 2	<ul style="list-style-type: none"> • Company Profile (Not more than 3 pages) • As required
C	CREDENTIAL	CREDENTIAL 1	Order copies as per Clause no. 7 of Section – B
		CREDENTIAL 2	<ul style="list-style-type: none"> • Product brochure • Other documents, if any
D	DECLARATION	DECLARATION 1	List of Clients as per format (Section – M)
		DECLARATION 2	Financial Capability of Bidder as per format (Section – J)
		DECLARATION 3	Bidder's Details as per format (Section – K)
		DECLARATION 4	Details of Order Execution as per format (Section – I)
		DECLARATION 5	As required
F	FINANCIAL INFO	P/L & BALANCE SHEET 2021-2022	P/L & BALANCE SHEET 2021-2022
		P/L & BALANCE SHEET 2022-2023	P/L & BALANCE SHEET 2022-2023
		P/L & BALANCE SHEET 2023-2024	P/L & BALANCE SHEET 2023-2024

WEBEL TECHNOLOGY LIMITED

SECTION – H

BILL OF MATERIAL

Sl. No.	Item Description	Qty.	Units.
1	Survey, Design and Engineering, Manufacture/ Procurement, Supply and Delivery, Installation, Testing and Commissioning Including 05 (FIVE) Years Comprehensive Maintenance of Grid Connected Rooftop Solar PV Power System with Cumulative Capacity 60 KWP at Dakshin Dinajpur Zilla Parishad (DDZP) office Building on Turnkey basis.	60	KWp.
2	Survey, Design and Engineering, Manufacture/ Procurement, Supply and Delivery, Installation, Testing and Commissioning Including 05 (FIVE) Years Comprehensive Maintenance of Grid Connected Rooftop Solar PV Power System with Cumulative Capacity 10 KWP at Dakshin Dinajpur Zilla Parishad (DDZP) office Building on Turnkey basis.	10	KWp
3	Survey, Design and Engineering, Manufacture/ Procurement, Supply and Delivery, Installation, Testing and Commissioning Including 05 (FIVE) Years Comprehensive Maintenance of Grid Connected Rooftop Solar PV Power System with Cumulative Capacity 10 KWP at Dakshin Dinajpur Zilla Parishad (DDZP) office Building on Turnkey basis.	10	KWp

WEBEL TECHNOLOGY LIMITED

SECTION - I

TECHNICAL SPECIFICATION WITH COMPLIANCE STATEMENT

(Tender No. WTL/DDZP/SOLAR/25-26/017)

A. Details of Solar PV

Sl. No.	Component	Details	Specification (Quoted / Applicable – by the bidder)	Complied (Yes / No)
1	Maximum Power (Pm)	585W		
	Maximum Power Voltage (Vm)	43.86		
	Maximum Power Current (Im)	13.34		
	Open Circuit Voltage (Voc)	51.14		
	Short Circuit Current (Isc)	13.90		
	Module Efficiency (m)	22.65%		
	Irradiance	1000W/m ²		
	Module Temperature	25°C		
	Type of System	Grid Connected		
	Expected life of Power Plant	25 Years		

B. Details of Inverter

Sl. No.	Component	Details	Specification (Quoted / Applicable – by the bidder)	Complied (Yes / No)
1	Max. recommended PV Power (for Module STC)	78000W		
	Max. DC Voltage	1100V		
	Start Voltage	250V		
	Nominal Voltage	600V		
	MPPT Voltage Range	200V-1000V		
	No. of PV strings per MPP tracker	3/4 + 4+ 4		
	Max. input current per MPP tracker	50A/50A/50A		
	Max. short-circuit current per MPP tracker	55A		
	Warranty	5 Years		

WEBEL TECHNOLOGY LIMITED

SECTION - J

DETAILS OF ORDERS EXECUTED BY BIDDER

(Tender No. WTL/DDZP/SOLAR/25-26/017)

Sl. No.	Order No.	Order Date	Order Value	Brief description of items and job details	Completed (Yes/NO)	Name of the Customer	Contact details of the Customer

Authorized Signatory (Signature In full): _____

Name and title of Signatory: _____

Stamp of the Company: _____

Note:

- A. Type of Project shall indicate the "Similar Nature of Work".
- B. Scope of work shall indicate whether it is structural installation, Operation or maintenance.
- C. Submit Customer Order Copy details of the order indicating the project value, customer contact details.

WEBEL TECHNOLOGY LIMITED

SECTION – K

FINANCIAL CAPABILITY OF BIDDER

(Tender No. WTL/DDZP/SOLAR/25-26/017)

FINANCIAL INFORMATION

Sl. No.	Name of the Bidder	Turnover (Rs. / Crores)		
		2021-22	2022-23	2023-24
1				

Authorized Signatory (Signature In full): _____

Name and title of Signatory: _____

Stamp of the Company: _____

Note:

Submit the audited financial statement/ audited annual report of the last three financial years.

WEBEL TECHNOLOGY LIMITED

SECTION – I

BIDDERS'S DETAILS

(Tender No. WTL/DDZP/SOLAR/25-26/017)

1	Name of the Firm	
2	Registered Office Address	
	Contact Number	
	Fax Number	
	E-mail	
3	Correspondence / Contact address	
	Name & Designation of Contact person	
	Address	
	Contact Number	
	Fax Number	
	E-mail	
4	Is the firm a registered company? If yes, submit documentary proof	
	Year and Place of the establishment of the company	
6	Former name of the company, if any	
7	<p>Is the firm</p> <ul style="list-style-type: none"> ▪ a Government/ Public Sector Undertaking ▪ a propriety firm ▪ a partnership firm (if yes, give partnership deed) ▪ a limited company or limited corporation ▪ a member of a group of companies, (if yes, give ▪ name and address and description of other companies) ▪ a subsidiary of a large corporation (if yes give the name and address of the parent organization). If the company is subsidiary, state what involvement if any, will the parent company have in the project. 	
8	Is the firm registered with Sales Tax department? If yes, submit valid GST Registration certificate.	
9	Is the firm registered for Service Tax with Central Excise Department (Service Tax Cell)? If yes, submit valid Service Tax registration certificate.	
10	Total number of employees. Attach the organizational chart showing the structure of the organization.	
11	Are you registered with any Government/ Department/ Public Sector Undertaking (if yes, give details)	
12	How many years has your organization been in business under your present name? What were your fields when you established your organization	
13	<p>What type best describes your firm? (Purchaser reserves the right to verify the claims if necessary)</p> <ul style="list-style-type: none"> ▪ Manufacturer ▪ Supplier ▪ System Integrator ▪ Consultant 	

WEBEL TECHNOLOGY LIMITED

	<ul style="list-style-type: none">▪ Service Provider (Pl. specify details)▪ Software Development▪ Total Solution provider (Design, Supply , Integration, O&M)▪ IT Company	
14	Number of Offices in district head quarters in West Bengal	
15	Is your organization has ISO 9001:2015 certificates?	
16	List the major clients with whom your organization has been / is currently associated.	
17	Have you in any capacity not completed any work awarded to you? (If so, give the name of project and reason for not completing the work)	
18	Have you ever been denied tendering facilities by any Government / Department / Public sector Undertaking? (Give details)	

Authorized Signatory (Signature In full): _____

Name and title of Signatory: _____

Company Rubber Stamp: _____

WEBEL TECHNOLOGY LIMITED

SECTION – M

Checklist for Eligibility / Qualification Criteria Compliance

(Tender No. WTL/DDZP/SOLAR/25-26/017)

Sl. No.	Specific Requirement	Documents Required	Compliance (Yes / No)
1.	The bidder must be a company registered under Companies Act, 1956/2013 or Partnership or LLP or Proprietary Firm and operational last 5 (Five) years as on 31st March 2025. Documentary (Certificate of incorporation/Relevant document) evidence to be submitted.	Certificates of incorporation / Registration Certificates.	
2.	The bidder should have own registered office presence in Kolkata/ Dinazpur District of last 5 years supporting documents to be submitted.	Relevant document	
3.	The bidder should have valid Trade License, GST Registration Number & PAN. Bidder shall have to submit photocopy of the documents.	<ul style="list-style-type: none">• GST Registration Certificate• PAN• Trade License• Other documents as required	
4.	The bidder should have valid PF & ESI registration certificate. Copy of the valid certificate to be submitted.	Relevant document	
5.	The bidder should have executed “Similar Nature Work” of single order an amount not less than Rs. 30.00 (Thirty Lakh) in last three financial years (FY – 2021-22, 2022-23, 2023-24) in Government Department / PSU / Autonomous Body/ any reputed organization. References order copy for the project to be provided.	Copy of Work Orders or Project Completion Certificate	
6.	The bidder should have average annual turnover of not less than Rs. 3.00 (Three crores) in the last three financial years (FY – 2021-22, 2022-23, 2023-24) Bidder shall have to submit Audited Balance Sheet / Audited Accounts / Auditor Certificate	Relevant document	
7.	The bidder should have positive net worth each year in the last financial years (FY – 2023-24). Auditor Certificate to be submitted.	Auditor Certificate to be submitted.	
8.	Respective OEM's shall submit NIT Declaration (Section – S) duly signed by the authorized signatory of the respective OEM as per the format. Deviation in format may not be accepted and will be considered as not eligible bid.	MAF of OEMs	
9.	The bidder shall not have been blacklisted by any State/Central Government or PSU or bilateral/ multilateral funding agencies for breach of ethical conduct or fraudulent practices as on date of submission of the proposal (as per DIT guidance note issued on 26-Dec-2011). Declaration on bidder's letter head to be submitted.	A self-certified declaration in this regard on Letter Head	
10.	The Bidder shall submit Bid Form (Section-E) duly	Bid form (Section-E)	

WEBEL TECHNOLOGY LIMITED

	signed by the authorised signatory of the company as per the format enclosed. Deviation in format may not be accepted.		
11.	Bidder shall submit NIT declaration (Section-Q) duly signed by the authorised signatory of the company as per the format. Deviation in format may not be accepted.	NIT Declaration (Section - Q)	
12.	The Bidders must have valid Quality Certifications of ISO 9001:2015. Bidders to submit copies of valid Certificates.	Valid Certificate	

Authorized Signatory (Signature In full): _____

Name and title of Signatory: _____

Company Rubber Stamp: _____

WEBEL TECHNOLOGY LIMITED

SECTION – O

PROFORMA FOR PERFORMANCE BANK GUARANTEE

(On non-judicial stamp paper of appropriate value to be purchased in the name of executing Bank)

PROFORMA OF BANK GUARANTEE FOR SECURITY DEPOSIT –CUM-PERFORMANCE GUARANTEE

Ref Bank Guarantee no.....

Date.....

PROFORMA OF BG FOR SECURITY DEPOSIT

KNOW ALL MEN BY THESE PRESENTS that in consideration of WEBEL TECHNOLOGY LIMITED, a Government of West Bengal Undertaking incorporated under the Companies Act, 1956 having its Registered office at Plot 5, Block BP, Sector V, Kolkata-700 091 (hereinafter called "The Purchaser") having agreed to accept from _____ (hereinafter called "The Contractor") Having its Head Office at _____, a Bank guarantee for Rs. _____ in lieu of Cash Security Deposit for the due fulfillment by the Contractor of the terms & conditions of the Work Order No. _____ dated _____ issued by the Purchaser for _____ (hereinafter called "the said work order _____ dated _____)". We _____ (Name & detailed address of the branch) (hereinafter called "the Guarantor") do hereby undertake to indemnify and keep indemnified the Purchaser to the extent of Rs. _____ (Rupees _____) only against any loss or damage caused to or suffered by the Purchaser by reason of any breach by the Contractor of any of the terms and conditions contained in the said Work Order No. _____ dated _____ of which breach the opinion of the Purchaser shall be final and conclusive.

(2) AND WE, _____ DO HEREBY Guarantee and undertake to pay forthwith on demand to the Purchaser such sum not exceeding the said sum of _____ Rupees _____) only as may be specified in such demand, in the event of the Contractor failing or neglecting to execute fully efficiently and satisfactorily the order for _____ Work Order no. , _____ dated _____

(3) WE _____ further agree that the guarantee herein contained shall remain in full force and effect during the period that would be taken for the performance of the said order as laid down in the said Work Order No. _____ dated _____ including the warranty obligations and that it shall continue to be enforceable till all the dues of the Purchaser under or by virtue of the said Work Order No. _____ dated _____ have been fully paid and its claims satisfied or is charged or till the Purchaser or its authorized representative certified that the terms and conditions of the said Work Order No. _____ dated _____ have been fully and properly carried out by the said contractor and accordingly discharged the guarantee.

(4) We _____ the Guarantor undertake to extend the validity of Bank Guarantee at the request of the contractor for further period of periods from time to time beyond its present validity period failing which we shall pay the Purchaser the amount of Guarantee.

(5) The liability under the Guarantee is restricted to Rs. _____ (Rupees _____) only and will expire on _____ and unless a claim in writing is presented to us or an action or suit to enforce the claim is filled against us within 6 months from _____ all your rights will be forfeited and we shall be relieved of and discharged from all our liabilities (thereinafter)

WEBEL TECHNOLOGY LIMITED

(6) The Guarantee herein contained shall not be determined or affected by liquidation or winding up or insolvency or closer of the Contractor.

(7) The executants has the power to issue this guarantee on behalf of Guarantor and holds full and valid power of Attorney granted in his favour by the Guarantor authorizing him to execute the Guarantee.

(8) Notwithstanding anything contained herein above, our liability under this guarantee is restricted to Rs. _____ (Rupees _____) only and our guarantee shall remain in force up to _____ and unless a demand or claim under the guarantee is made on us in writing on or before _____ all your rights under the guarantee shall be forfeited and we shall be relieved and discharged from all liabilities there under.

WE, _____ lastly undertake not to revoke this guarantee during the currency except with the previous consent of the Purchaser in writing. In witness whereof we _____ have set and subscribed our hand on this _____ day of _____.

SIGNED, SEALED AND DELIVERED

(Stamp of the executants)

WITNESS

1) _____

2) _____

(Name & address in full with Rubber Stamp)

WEBEL TECHNOLOGY LIMITED

INSTRUCTIONS FOR FURNISHING BANK GUARANTEE

1. Bank Guarantee (B.G.) for Advance payment, Mobilization Advance, B.G. for security Deposit-cum-Performance Guarantee, Earnest Money should be executed on the Non-Judicial Stamp paper of the applicable value and to be purchased in the name of the Bank.
2. The Executor (Bank authorities) may mention the Power of Attorney No. and date of execution in his/her favour with authorization to sign the documents. The Power of Attorney is to be witnessed by two persons mentioning their full name and address.
3. The B.G. should be executed by a Nationalised Bank/ Scheduled Commercial Bank preferably on a branch located in Kolkata. B.G. from Co-operative Bank / Rural Banks is not acceptable.
4. A Confirmation Letter of the concerned Bank must be furnished as a proof of genuineness of the Guarantee issued by them.
5. Any B.G. if executed on Non-Judicial Stamp paper after 6 (six) months of the purchase of such stamp shall be treated as Non-valid.
6. Each page of the B.G. must bear signature and seal of the Bank and B.G. Number.
7. The content of the B.G. shall be strictly as Proforma prescribed by WTL in line with Purchase Order /LOI/ Work Order etc. and must contain all factual details.
8. Any correction, deletion etc. in the B.G. should be authenticated by the Bank Officials signing the B.G.
9. In case of extension of a Contract the validity of the B.G. must be extended accordingly.
10. B.G. must be furnished within the stipulated period as mentioned in Purchase Order / LOI / Work Order etc.
11. Issuing Bank / The Bidder are requested to mention the Purchase Order / Contract / Work Order reference along with the B.G. No. For making any future queries to WTL.

WEBEL TECHNOLOGY LIMITED

SECTION - P

SERVICE LEVEL AGREEMENT

(Tender No. WTL/DDZP/SOLAR/25-26/017)

Agreement for SLA will be signed between WTL and selected bidder before releasing the workorder/purchase order.

Service Level Agreement for Installation of Grid-Connected Rooftop Solar Panel at Dakshin Dinajpur Zilla Parishad office Building, Government of West Bengal.

2 business day resolution for Kolkata PIN code area & 3 business day resolution for rest of West Bengal with 95% uptime of Unified Labour Database. SLA calculation with monthly basis. Penalty amount will be deducted from PBG.

Resolution within	Penalty
<= 2 business day	Nil
>2 business days to <7 business days	Per day Rs. 100.00
> 7 business days to <15 business days	Per day Rs. 150.00
> 15 business days to < 21 business days	Per day Rs. 200.00
>21 business days	Per day Rs. 300.00

WEBEL TECHNOLOGY LIMITED

SECTION - Q

NIT DECLARATION FOR BIDDER

(Bidders are requested to furnish the Format given in this section, filling the entire Blank and to be submitted on Bidder's Letter Head)

To
Webel Technology Limited
Plot – 5, Block – BP, Sector - V,
Salt Lake City,
Kolkata – 700091.

**Sub: Installation of Grid-Connected Rooftop Solar Panel at Dakshin Dinajpur
Zilla Parishad office Building, Government of West Bengal.**

Dear Sir,

We the undersigned bidder/(s) declare that we have read and examined in details the specifications and other documents of the subject Tender No. WTL/DDZP/SOLAR/25-26/017 dated 08.08.2025 for Installation of Grid-Connected Rooftop Solar Panel at Dakshin Dinajpur Zilla Parishad office Building, Government of West Bengal published by Webel Technology Limited in e-Tender website.

We further declare that we have agreed and accepted all the clauses / sub-clauses / formats / terms & conditions other requirements related to the said tender and we will abide by the same as mentioned in the tender document while participating and executing the said tender.

Thanking you, we remain

Yours faithfully

.....
Signature

.....
Name in full

.....
. Designation

.....
Company Stamp

Dated, thisday of2025

WEBEL TECHNOLOGY LIMITED

SECTION – R

PRE-BID MEETING QUERY

(Tender No. WTL/DDZP/SOLAR/25-26/017)

Name of the Bidder:

Queries

Sl. No.	Section No.	Clause No.	Page No.	Queries

Note: The filled form to be submitted in XLS or PDF Format. There is a cut off date for receiving of queries before Pre Bid Meeting. Queries received after the cutoff period will not be accepted. The Purchaser reserves the right to respond all queries over e-mail.

Authorized Signatory (Signature In full): _____

Name and title of Signatory: _____

Company Rubber Stamp: _____

WEBEL TECHNOLOGY LIMITED

SECTION – S

MANUFACTURER’S AUTHORIZATION FORM

Date:

To
Webel Technology limited
Plot-5, Block-BP, Sector-V
Salt Lake
Kolkata-700 091

Ref: Tender No.: Tender No. WTL/DDZP/SOLAR/25-26/017 dated 08.08.2025

WHEREAS _____ who are official producers of _____ and having production facilities at _____ do hereby authorize _____ located at _____ (hereinafter, the “Bidder”) to submit a bid of the following Products produced by us, for the Supply Requirements associated with the above Invitation for Bids.

When resold by _____, these products are subject to our applicable standard end user warranty terms.

We assure you that in the event of _____, not being able to fulfill its obligation as our Service Provider in respect of our standard Warranty Terms we would continue to meet our Warranty Terms through alternate arrangements.

We also confirm that _____ is our authorized service provider/system integrator and can hence provide maintenance and upgrade support for our products.

We also confirm that the products quoted are on our current product list and are not likely to be discontinued within 3 years from the day of this letter. We assure availability of spares for the products for the next two years after three years warranty.

We also confirm that the material will be delivered as per delivery schedule against above mentioned tender from the date of placement of confirmed order.

Name _____ In the capacity of _____

Signed _____

Duly authorized to sign the authorization for and on behalf of _____

Dated on _____ day of _____ 2025

Note: This letter of authority must be on the letterhead of the Manufacturer and duly signed by an authorized signatory.